

B220 Series

Weigh & Count Scales



- ◆ **Counting Function**– forward and reverse. Simple count and accumulate operation.
- ◆ **Display**– Backlit for clear visibility.
- ◆ **Power**– Battery and AC operation.
- ◆ **Load Cell Technology**– Patented high resolution technology at an affordable price.

VALUE IN
WEIGHING



B220 Series Weigh & Count Scales

Features

- Versatile sampling routines**— Enter the count mode by pre-determined sample sizes, keypad entry, or piece weight entry. Reverse sampling determines counts without emptying your container.
- Limit alarm**— Audible alarm lets you know when a pre-determined count has been reached.
- Keypad**— Membrane keypad with audible and tactile feedback.
- Part look-up**— Store piece weights and tare weights from up to 32 parts for quick recall. In addition, 7 "Hotshot" keys allow you to quickly recall piece weights and tare weights of your most commonly counted parts.
- Accumulator**— Single accumulator lets you track total count and number of transactions.
- Battery operation**— 6 x 1.5 V "D" size batteries (not included) provide up to 800 hrs. of continuous use. Sleep mode will increase battery life.

Specifications

Capacity	Displayed Weight Resolution
15 lb	0.0005 lb
30 lb	0.001 lb
60 lb	0.002 lb

- Internal Resolution**— 1:1.5 million counts
- Displayed Count**— 9,999,999
- Housing**— Light gray ABS with stainless steel shroud
- Base**— Black high-impact polystyrene
- Display**— 7 segment, 7 digit LCD display with back light
- AC adapter**— 15 VDC @ 3000 mA
- Certifications**— Tested to comply with FCC standards.

Dimensions

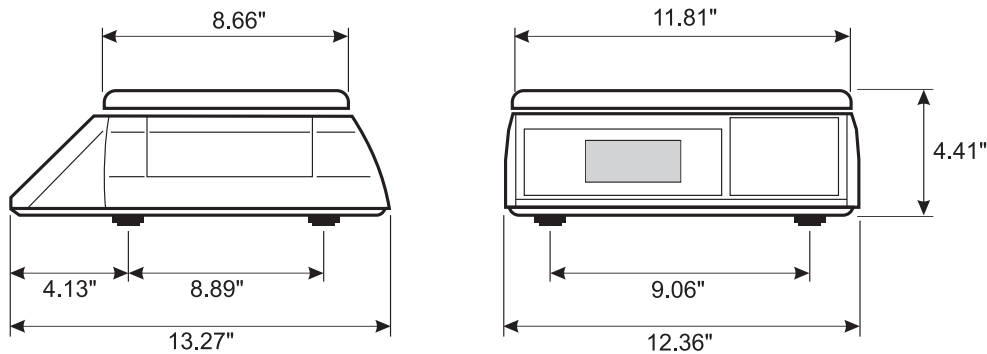

Salter Brecknell Weighing Products



a division of Avery Weigh-Tronix
1000 Armstrong Dr.
Fairmont, MN 56031
Toll free: 800-637-0529
Tel: 507-238-8702 Fax: 507-238-8271
e-mail: sales@salterbrecknell.com
www.salterbrecknell.com