



Easily weigh drum barrels and industrial containers



Built-in handles for portability



Easy roll on and roll off

R SERIES

Drum Scale

The CAS R Series Drum Scale is a portable platform scale with easy access ramps on two sides. Weigh drum barrels or any industrial container. Side rails assist in keeping items on the weighing platform.

Combine the heavy duty R Series Drum Scale with CAS quality and get years of trouble free service.



R SERIES | Drum Scale

SPECIFICATIONS

Model	R-250	R-500
Capacity	500 x 0.2 lbs	1,000 x 0.5 lbs
External Resolution	1/2,500	1/2,000
Platform Size (inch/mm)	31.5 x 30.5 / 800.1 x 774.7	
Overall Dimensions	inch: 42.75 (W) x 39.5 (D) x 3.5 (H)	
	mm: 1085.9 (W) x 1000.3 (D) x 88.9 (H)	
Product Weight	121 lbs / 54.9 kg	

FEATURES

- Anti-Skid diamond plate deck
- Mild steel construction
- High quality powder coated finish
- Portable with easy to use handles
- Two built-in rubber wheels for easy transport
- Ramps on 2 sides for easy entrance/exit
- Side access junction box
- Top access adjustable feet
- 18 ft shielded cable
- Side Rails

OPTIONS

- CI-2001 Series Indicators
- Indicator Stand
- DEP-50 Receipt Printer



Optional CAS Indicators



With its easy to use Quick Connect Cable, quickly hook up your R Series Drum Scale to a CAS CI-2001A/B Series Indicator.



Portability



The light weight R Series Drum Scale has two heavy duty handles and two rubber wheels built into the frame.



Need to move your scale? No problem. Pick it up and roll it. It's that easy!

DIMENSIONS

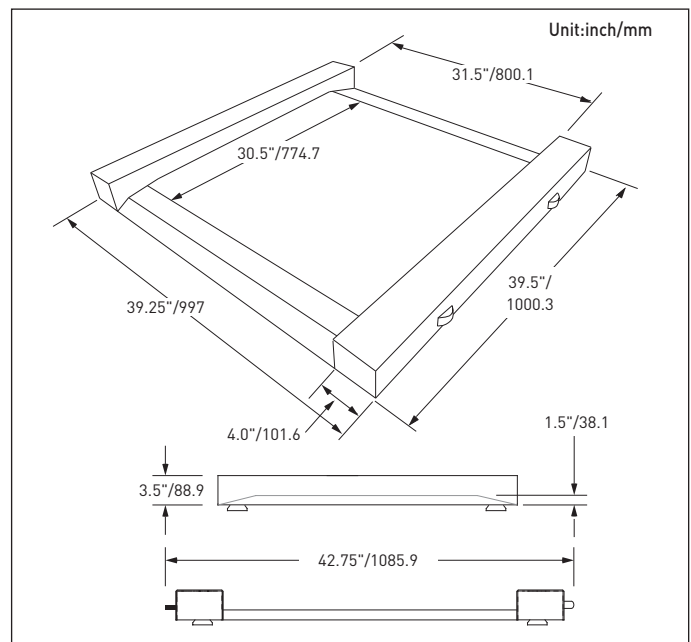

CAS

CAS USA Corporation
Corporate Office

99 Murray Hill Parkway
East Rutherford, NJ 07073
Tel: (201) 933-9002
Fax: (201) 933-9025
<http://www.cas-usa.com>

