

BenchMark™ HDP Portable Heavy Duty Bench Scales

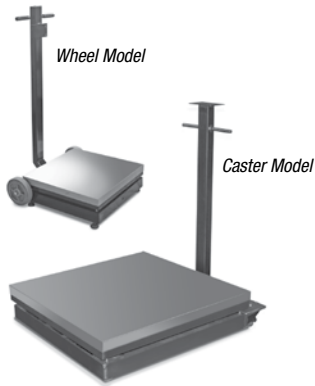

STANDARD FEATURES

- Mild steel base construction
- 304 stainless steel cover
- Indicator stand for mounting IQ plus 355, IQ plus 390-DC, IQ plus 590-DC and 480 Legend
- Wheel Model
- Polyurethane rubber leveling feet with stainless steel stems
- 8 in diameter preformed rubber wheels with ball bearings
- Caster Model
- 3 1/2 in diameter preformed rubber casters, two fixed, two swivel with lock



Ideal for Aviation Weighing. A complete system can be sold with the Tracer® AV. Reference Aviation section for specifications

APPROVALS



Measurement
Canada
Approved



SPECIFICATIONS

Load Cell, NTEP Certified:

Aluminum, environmentally sealed

Output Impedance:

350 ohms

Maximum Overload:

200%

Overload Protection:

Five-point, independently adjusted

Cable Length:

10 ft (3 m)

Compensated Temperature Range:

14°F to 104°F (-10°C to 40°C)

Warranty:

Two-year limited warranty

Approvals:

NTEP CC 06-010, Class III 5,000d

Measurement Canada AM-5625, Class III 5,000d

PART NUMBER/PRICE

PART #	CAPACITY	PLATFORM DIMENSIONS	EST. SHIP WEIGHT	PRICE
Wheel Model				
97072	250 lb (125 kg)	24 x 24 x 8.75 in	275 lb	Consult
97073	500 lb (225 kg)	24 x 24 x 8.75 in	275 lb	Consult
Caster Model				
97074	250 lb (125 kg)	24 x 24 x 9.31 in	290 lb	Consult
97075	500 lb (225 kg)	24 x 24 x 9.31 in	290 lb	Consult

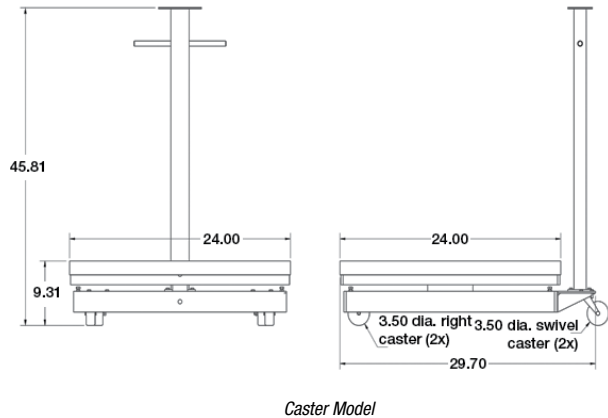
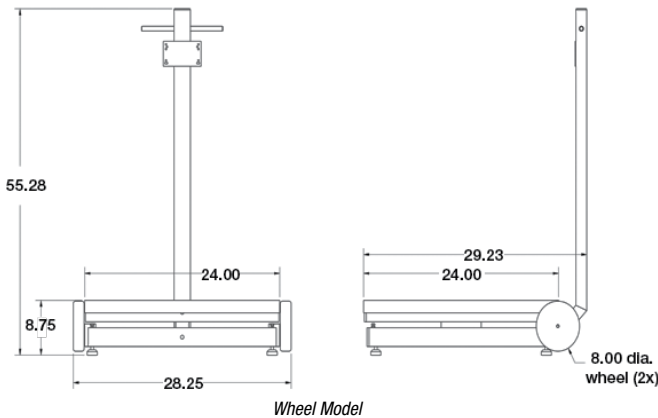

BENCH SCALES